

TEMPORARY STRAINER DIMENSIONS

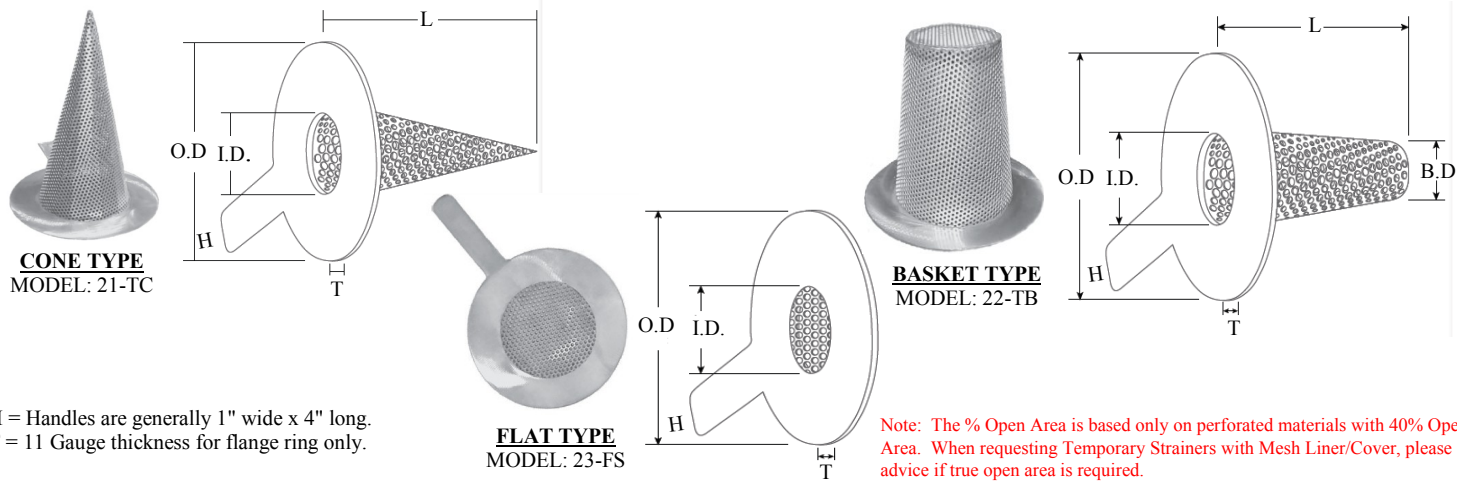

* Please provide flange/pipe wall schedule to determine I.D. dimension. * Below lengths are based "only" on 1/8" Perf. on 3/16" Centers Stg.

Nominal Pipe Size	O.D.					I.D.	CONE LENGTH "L"				BASKET LENGTH "L"				B.D.
	150#	300#	*600#	*900#	*1500#		100%	150%	200%	300%	100%	150%	200%	300%	
3/4	2.125"	2.50"	2.50"	2.625"	2.625"	0.625"	3.00"	4.00"	5.00"	6.00"	1.50"	2.00"	3.00"	4.00"	0.50"
1	2.50"	2.75"	2.75"	3.00"	3.00"	0.75"	3.00"	4.00"	5.00"	6.00"	1.50"	2.00"	3.00"	4.00"	0.75"
1 1/2	3.25"	3.625"	3.625"	3.75"	3.75"	1.25"	3.50"	4.50"	6.00"	9.00"	2.00"	2.50"	3.50"	5.00"	0.75"
2	4.00"	4.25"	4.25"	5.50"	5.50"	1.75"	4.00"	6.00"	8.00"	11.00"	2.50"	3.00"	4.00"	6.00"	1.00"
2 1/2	4.75"	5.00"	5.00"	6.375"	6.375"	2.25"	4.00"	6.00"	8.00"	11.00"	2.50"	3.00"	4.50"	6.00"	1.25"
3	5.25"	5.75"	5.75"	6.50"	6.75"	2.75"	5.00"	7.00"	9.00"	13.00"	3.00"	4.50"	6.00"	8.00"	1.50"
4	6.75"	7.00"	7.50"	8.00"	8.125"	3.75"	8.00"	10.00"	12.00"	18.00"	4.00"	5.00"	7.00"	11.00"	2.00"
5	7.625"	8.375"	9.375"	9.625"	9.875"	4.625"	8.00"	11.00"	14.00"	22.00"	4.50"	7.00"	9.00"	14.00"	2.50"
6	8.625"	9.75"	10.375"	11.25"	11.00"	5.375"	9.00"	13.00"	18.00"	25.00"	5.50"	8.00"	11.00"	17.00"	3.00"
8	10.875"	12.00"	12.50"	14.00"	13.75"	7.375"	12.00"	17.00"	23.00"	33.00"	7.00"	11.00"	14.00"	21.00"	4.00"
10	13.25"	14.125"	15.625"	17.00"	17.00"	9.375"	14.00"	21.00"	28.00"	41.00"	8.00"	13.00"	17.00"	26.00"	5.00"
12	16.00"	16.50"	17.875"	19.50"	20.375"	11.00"	16.00"	25.00"	34.00"	49.00"	10.00"	15.00"	20.00"	31.00"	6.00"
14	17.375"	19.00"	19.00"	20.375"	22.625"	12.25"	18.00"	27.00"	36.00"	53.00"	10.00"	16.00"	22.00"	33.00"	7.00"
16	20.125"	21.125"	21.875"	22.50"	25.125"	14.00"	21.00"	31.00"	40.00"	61.00"	12.00"	19.00"	24.00"	37.00"	8.00"
18	21.25"	23.375"	23.75"	25.00"	27.625"	15.75"	24.00"	35.00"	46.00"	68.00"	14.00"	21.00"	27.00"	41.00"	9.00"
20	23.50"	25.625"	26.625"	27.375"	29.625"	17.50"	26.00"	38.00"	51.00"	76.00"	16.00"	24.00"	31.00"	48.00"	10.00"
24	27.875"	30.375"	30.875"	32.875"	35.375"	21.25"	31.00"	45.00"	61.00"	90.00"	18.00"	28.00"	37.00"	57.00"	12.00"

Larger sizes available, please consult factory.

NOTES:

1. STANDARD TEMPORARY STRAINER MATERIALS ARE STAINLESS STEEL AND CARBON STEEL; HOWEVER, OTHER MATERIALS ARE AVAILABLE UPON REQUEST.
2. STANDARD PERFORATED MATERIAL THICKNESS: RANGES BETWEEN 14 GA TO 20 GA. FLANGE RINGS 11 GA. HEAVIER GAUGE AVAILABLE FOR PERFORATED AND/ OR RINGS.
3. PERFORATION: HOLE SIZES 1/16" AND UP.
4. FLANGE FACINGS: RAISED FACE AND RTJ AVAILABLE.
5. LINERS/COVERS: 10 MESH AND UP. STANDARD MESH IS 304SS.
6. SPECIAL LENGTHS ARE AVAILABLE.

SPECIAL 3-PLY COMPRESSOR SUCTION STRAINERS ARE ALSO AVAILABLE.